



Chef'sTable

SMART STORAGE FOR KITCHEN APPLIANCES.



Product Informationen



Space-saving innovation – maximum flexibility

Thanks to the intelligent swivel mechanism, the worktop remains free of unused kitchen appliances without having to sacrifice quick access. With a load capacity up to 16kg, the ChefsTable provides a stable work surface, even for heavy machines such as the Thermomix. Simply swivel back after use for a tidy look and more space.



Easy installation – perfect for any kitchen

ChefsTable is designed for base cabinets from 400 to 600 mm wide and can be easily retrofitted. The fitting is suitable for installation behind hinged doors - screw on the left and right, attach the synchro rod, attach the work surface - done! A pull-out underneath the ChefsTable can provide additional storage space for accessories.





All product benefits at a glance

- » Creates clear worktops and a clean look
- » Offers a sturdy work surface for devices weighing up to 16 kilogrammes
- » Can easily be retrofitted to existing kitchens

Features



SoftSTOPplus for damped closing plus self-closing of the fitting.

ChefsTable

ChefsTable

Consisting of:

- 1 set of power pack with lever arms
- 1 torsion bar
- 2 fixing sleeves for torsion bar
- 1 lifting handle
- 1 mounting material

Colour number:

Anthracite 9846

For cabinet width:

400 -
600 mm

Item no.

281902 9846

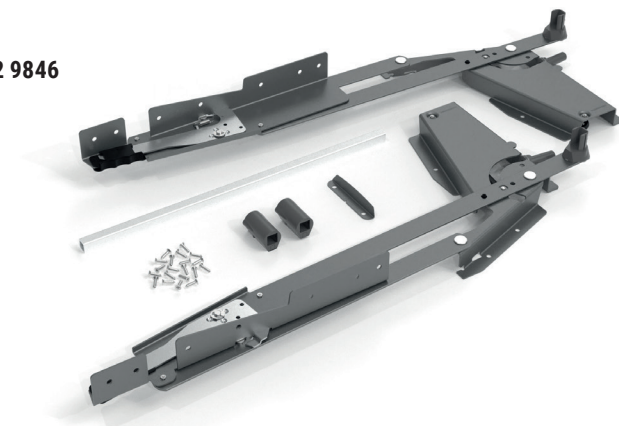



WWW.KESSEBOEHMER.COM

