

# Monteringsanvisningar Skjutdörrslås Hooky Zero

## KIT HOOKY ZERO K20, K25

### ASSEMBLING INSTRUCTIONS

1. Drill the panel as shown in the drilling diagram (pag. 4).

2. Enter the lock in the seat, taking care to orient aligned with the door (Fig.1).

3. Apply the two plastic supports of the plates recessed in their housing  $\varnothing 48$  (Fig. 2). The supports are inserted opposite and rotated  $180^\circ$  between them, in this way they engage each other, until their stopping on both sides of the door and adapting automatically to the thickness of the panel.

4. Place the 6mm spindle in his respective housing through the lock (Fig. 3), choosing between one of the two provided, according to the thickness of the door and possibly adapt the length:

$$L \text{ Spindle} = \text{Door Thickness} - 10\text{mm.}$$

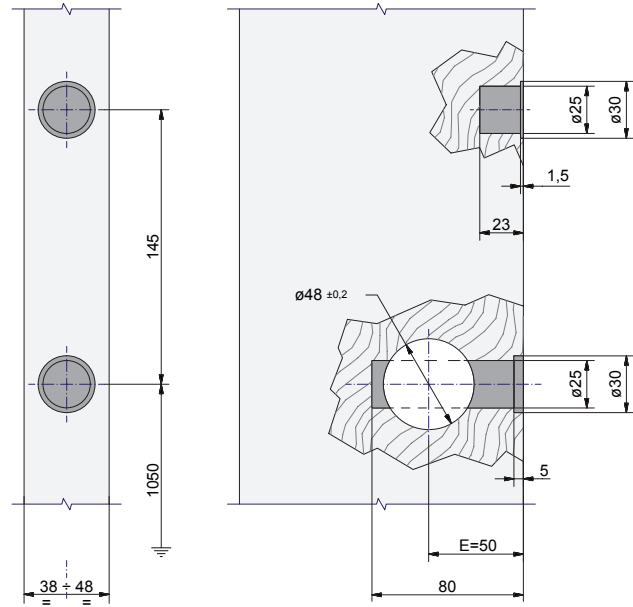

### HOUSING FOR COVER MILLING STRIKER

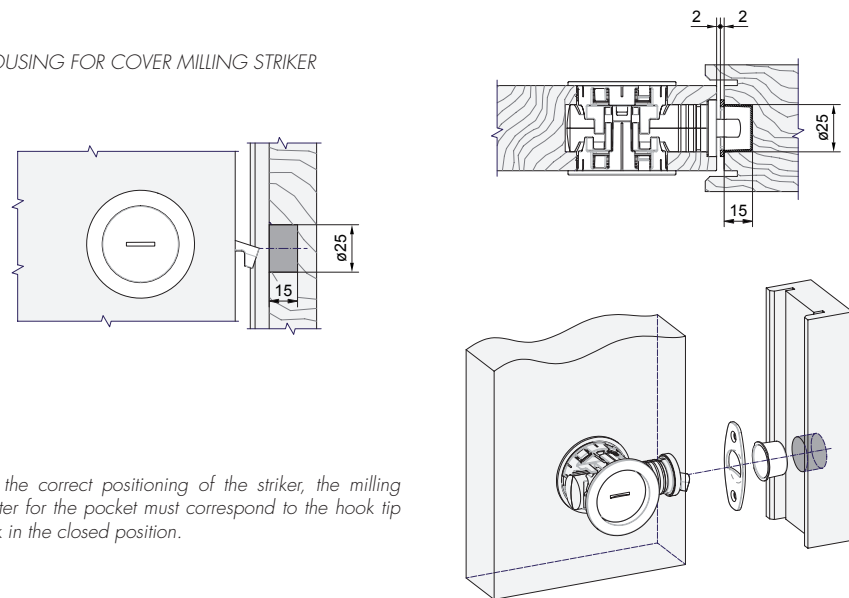

For the correct positioning of the striker, the milling center for the pocket must correspond to the hook tip lock in the closed position.

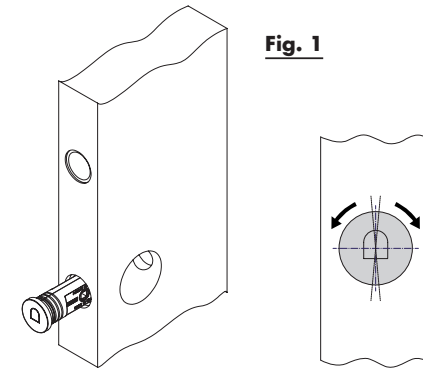

Fig. 1

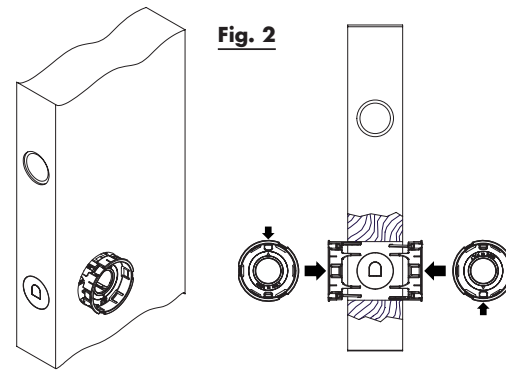

Fig. 2

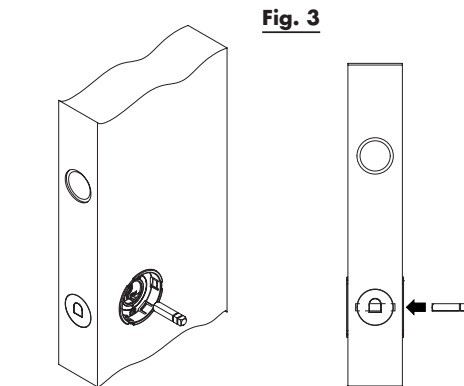

Fig. 3

5. Insert the knob and the emergency disc against the plastic supports until the engagement thereof.

6. Place the plates, round or square, pressing them until their stop clamping into the holders and against the surface of the panel.

7. Apply the pull handle in its seats.

8. Verify the correct working of the lock.

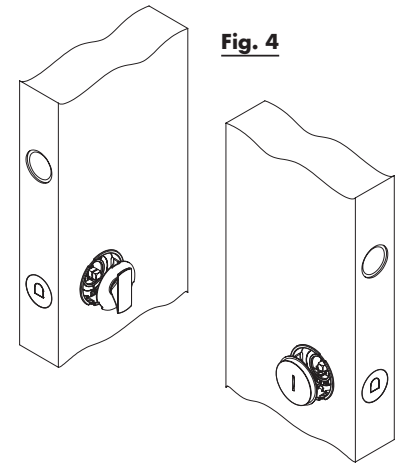

Fig. 4

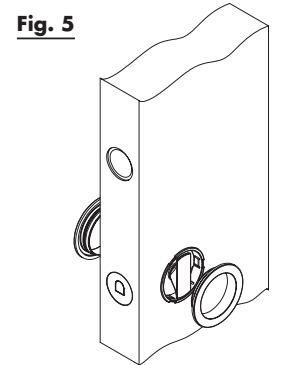

Fig. 5

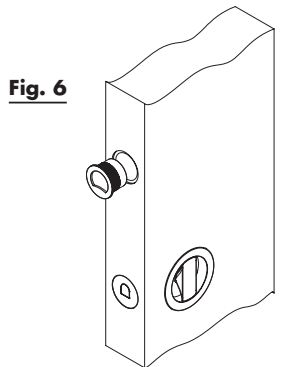

Fig. 6

